



NPP Mashproject LLC
Saint-Petersburg, Russia

CRACK DEPTH METER ELECTRO POTENTIAL

281M

Operation Manual
281M OM



TABLE OF CONTENTS

1. DESCRIPTION AND OPERATION	2
1.1 DESIGNATION	2
1.2 TECHNICAL CHARACTERISTICS	2
1.3 DELIVERY SET.....	3
1.4 STRUCTURE AND FUNCTIONING	3
1.4.1 <i>Operating principle</i>	3
1.4.2 <i>Crack depth meter structure</i>	4
1.4.3. <i>Crack depth meter design</i>	5
1.5 MARKING AND SEALING	6
1.6 PACKING.....	6
2. OPERATION	7
2.1 MEASUREMENT SEQUENCE	7
2.2 PREPARING THE DEVICE FOR OPERATION	9
2.3 DEVICE HANDLING ON THE PRODUCT	12
2.4 POWER SUPPLY CONTROL, CHARGING AND TURNING OFF THE DEVICE	12
3. TECHNICAL MAINTENANCE	13
4. TRANSPORTATION AND STORAGE	13
5. DISPOSAL	13
6. WARRANTY	14
7. ACCEPTANCE CERTIFICATE.....	15
ANNEX A (RECOMMENDED)	16

This operating manual contains the information on the purpose, operation principle, technical characteristics, construction and operation of the electro-potential 281ME Crack depth meter (hereinafter Crack depth meter) and the rules for its operation, transportation and storage.

1. DESCRIPTION AND OPERATION

1.1 Designation

The Crack depth meter is designed to perform the quality assurance of the metal items (including, stainless steel, duraluminium). The device measures the depth of cracks, emerged on the surface and previously detected by other methods.

1.2 Technical characteristics

Basic technical characteristics of the Crack depth meter are listed in Table 1.

Table 1

Parameter	Value
Crack depth measurement range	0.5 - 30 mm
Crack depth estimation range	30 - 100 mm
Measurement accuracy	$\pm(0.1h+0.2 \text{ mm})$, where h is a crack depth
Max crack opening	up to 3,5 mm depending on probe design
Min crack length	5 x crack depth, but not less than 3 mm
Curvature radius of test object surface (convex and concave)	not less than 4 mm
Power supply	3,6 V, 1,1A/h
Display backlight	yes
Automatic shutdown of the device	yes
Overall dimensions	150 × 80 × 30 mm
Weight	0,4 kg or less
The temperature range	+5 to +40 °C
Service life	5 years

1.3 Delivery set

Crack depth meter delivery set is given below in Table 2.

Table 2

Name	Quantity (pcs)	Notes
Electronic unit	1	
Probe «1x4»		Delivery is agreed upon when ordering
Probe «3+1»		Delivery is agreed upon when ordering
Probe «2x2»		Delivery is agreed upon when ordering
Power element: battery 3.6 V, 1.1A/h	1	Pre-installed
Charger	1	
KO-281-1 Reference block with cracks imitation	1	
Soft case and device arm cuff	1	
Operation manual	1	
Calibration certificate	1	
Carrying bag	1	
Additional accessories		
KO-281-2 Reference block		
Reference blocks with imitation of cracks of various depth		
Cordless grinding machine for preparation of control zone on the product surface		

1.4 Structure and functioning

1.4.1 Operating principle

The operating principle of the Crack depth meter is based on the electro-potential method.

Constant current value of 1.0 kHz is passed around the controlled crack by means of current electrodes. The voltage, that

appears as a result of the passage of current through the crack walls, is measured by receiving electrodes and the electronic unit. This voltage is proportional to the crack depth.

The electronic circuit diagram converts the signal from the Probe into user-friendly interface.

Measurements can be performed by a wide range of Probes (according to the Table 3).

Table 3

Name of the probe	Purpose	Crack depth
«1x4»	Basic probe	0.5 - 30 mm
«2x2»	For work in hard-to-reach places. (slender shafts, fillet transitions, etc.)	0.5 - 20 mm
«3+1»	To measure deep cracks in magnetic materials (steel, cast iron)	5.0 - 100 mm

1.4.2 Crack depth meter structure

The Crack depth meter contains a Probe, an electronic unit for receiving and converting signals from a Probe and a power unit.

The electrical signals in the Probe are converted into the digital code and directed into the controller microprocessor. The controller contains the random access memory (RAM) for storing intermediate calculation results, read-only memory (ROM) for recording the work program and a microprocessor for organizing the interconnection of the operation of all controller units and performing calculations.

All controller units are connected by the bidirectional data bus and unidirectional data bus of address and control.

Power supply of all controller units is provided by internal power supply.

Using the controller in the Crack depth meter allows to:

- receive the measurement result directly in millimeters on the graphic display;
- avoid the influence of the electromagnetic properties of the controlled item during the device operation. This increases the accuracy and stability of the control.

The structural diagram of the Crack depth meter is shown in Fig.1.

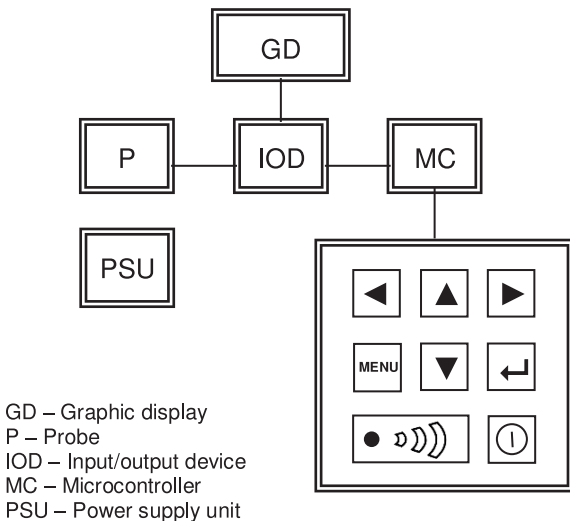

Figure 1

1.4.3. Crack depth meter design

The electronic unit of the Crack depth meter is made in the form of the portable type device.

On the front panel there are:

- graphic display (further Display),
- keyboard with buttons «▲» «▼» «◀» «▶», «MENU»,
- «↵» input of information,
- «Ⓜ» switching on/off of the Crack depth meter, transition of the processor operation to the start of program execution ("RESET"),
- «● Ⓜ)» LED indicator, ADA «DEFECT».

The Probe connector is located on the end wall. The battery cover is located on the rear panel.

A schematic representation of the Probes is shown in Fig. 2.

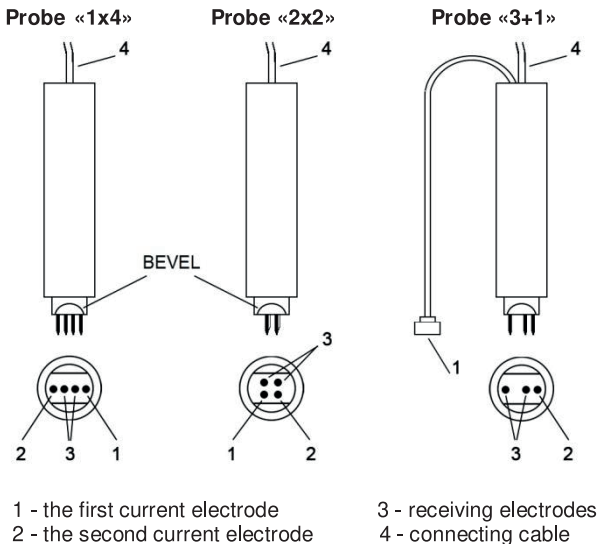

Figure 2

1.5 Marking and sealing

1.5.1. The electronic unit on the back side has a plate according, on which the following is indicated:

- name of the manufacturer;
- name of the Crack depth meter;
- serial number of the Crack depth meter.

1.5.2 The inscriptions, signs and images on the plate are made in the manner that ensures their safety during storage and during the operation of the product, on which the plate is installed.

1.6 Packing

The bag, included in the delivery set, is used for carrying and storing the Crack depth meter. The bag has elements for positioning and fixing the components, which are included in the delivery set.

2. OPERATION

2.1 Measurement sequence

2.1.1 Measurement or evaluation of the crack depth by the device is performed in two stages.

2.1.2 At the first stage, the current is measured at the flawless area, located away but near to the crack.

Measuring with Probes «1x4» and «2x2» is carried out in the free area of the product away from the crack at the distance of at least 10 mm from the crack.

The first current electrode of the Probe «3+1» must be located at a distance of at least 60 mm from the crack, and the nearest receiving electrode – at the distance of 10-15 mm from the crack.

The result of this step is the autocalibration of the device to the current, flowing through the crack.

It is recommended to carry out the measurements for the first stage several times to make sure that the readings are stable (the measurements at the first stage largely determine the error in measuring the cracks).

2.1.3 The second stage is the measurement of the crack depth.

The receiving electrodes of the Probes «1x4» and «2x2» should be located on both sides of the crack edges.

The receiving electrodes of the Probe «3+1» should be located on both sides of the crack edges, and the position of the first current electrode does not change (it stays on flawless area).

The result of measuring the depth of the crack in mm will appear on the device screen.

A schematic representation of the Probes is shown in Figures: the Probe «1x4» - Figure 3; the Probe «2x2» - Figure 4; the Probe «3+1» - Figure 5.

2.1.4 Before the measurements, user has to check the device operability on the control sample.

If electromagnetic properties of the controlled item differ significantly from the material of the control sample, it is necessary to make the additional control sample with the crack, corresponding to the upper limit of the expected crack depth and to adjust the device. Adjustment is retained for the whole service life of the device and can be changed by the User at any time.

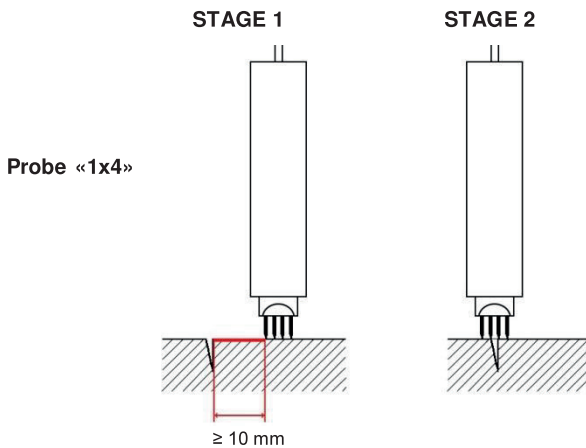
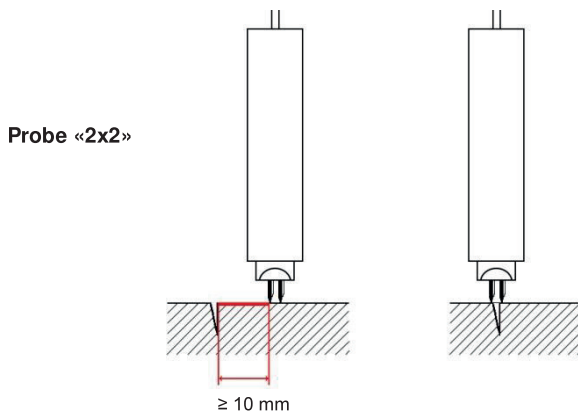
*Figure 3**Figure 4*

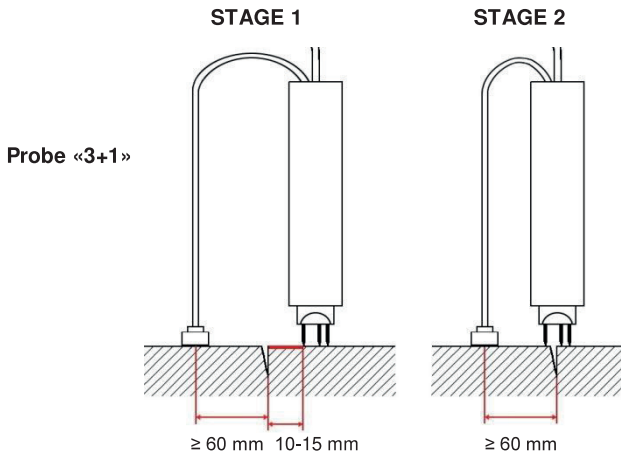

Figure 5

2.2 Preparing the device for operation

2.2.1. Check on the control sample.

Before each use of the device it is necessary to check its operability on the control sample.

Take a control sample. Clean the flawless area (for recording “zero” readings) and the crack area of the control sample to provide the electrical contact.

Connect the Probe to the device.

Switch on the device by briefly pressing the button « ① ». Display screen will appear as shown in Figure 6.

The first line of the screen shows the type of the tested material. Using the button « ▼ » the type of material can be changed.

The measurement result is displayed in the middle part of the screen.

The bottom line shows the type of the connected Probe. It also shows the battery condition by convention.

Press « ↵ ». «ZERO» appears on the screen.

Install the sensor according to the item 2.1.2

The value of the potential on the flawless area appears on the screen. After several readings remove the Probe from the control sample, press «↓».

The display screen will appear as shown in Figure 6.

Fe-metal	mm
0.0	
2x2	

Figure 6

Install the sensor according to the item 2.1.3 and make the measurement of the crack depth.

2.2.2 Setting the thresholds for the automatic crack depth alarm system.

Press «MENU». The display screen will appear as shown in Figure 7.

MAIN MENU	
Measurements	
Thresholds	
Correction	
Settings	
Off	

Figure 7

Using the buttons «▼» and «↓», select «Thresholds». Pressing the buttons «◀» «▶», the alarm mode («off» or «more») is selected.

If the "more" mode is selected, press the button «▼» to set the desired threshold level. Press «↓», set the cursor on the first digit of the threshold, then use the «▲» «▼» buttons to set its

value. Press «▶» to move the cursor to the second and third digits and set their values, then press the «↓» and «MENU» buttons to fix the selected mode.

2.2.3. Correction of the device readings.

If electromagnetic properties of the controlled item differ significantly from the material of the control sample, it is necessary to make the additional control sample with the crack, corresponding to the upper limit of the expected crack depth and to adjust the device.

Adjustment is retained for the whole service life of the device and can be changed by the User at any time.

Connect the Probe to the device.

Switch on the device by briefly pressing the button «①». The display screen will appear as shown in Figure 6.

With button «▼», choose the type of material closest in properties to the sample.

Press «MENU». Using «▼» and «↓», select «Correction». Then by «▲» «▼» and «↓» enter the correction mode by typing the following password «◀» «▶» «▲» «▲» and «↓».

«ZERO» appears on the screen.

Install the sensor according to the item 2.1.2

The value of the potential on the flawless area appears on the screen. After several readings remove the Probe from the control sample, make sure that the last measured value is saved on the screen and press the «↓».

The display screen will appear as shown in Figure 6 (without indicating the type of Probe and battery indicator).

Install the sensor according to the item 2.1.3 and make the measurement of the crack depth.

The value for the crack depth appears on the screen.

Remove the Probe from the control sample after several seconds of pressing, make sure that the last measured value is saved on the screen and press «↓».

By pressing «▲» «▼» set the desired value for the indication of the crack depth and press «↓». The message «Is executed the correction» will appear on the screen.

2.2.4 Delete the correction.

To delete the correction, enter the «Clean» mode, enter the password in sequence «◀» «▶» «▲» «▲» and «↵» and then perform the sequence of operations, indicated on the screen.

2.2.5. Device settings.

If it is necessary to change the auto-off time or the backlight time of the device screen, enter the «Settings» and then perform the sequence of operations, indicated on the screen.

2.3 Device handling on the product

2.3.1. Before measurement clean the flawless area of the defect-free area (for recording «ZERO» readings), the controlled area of the crack and area to locate the first current electrode of the Probe «3+1». The first current electrode must be at least 60 mm away from the crack.

2.3.2 Connect the Probe to the device.

Switch on the device by briefly pressing the button «①». Display screen will appear as shown in Figure 6.

Using the button «▼» the type of material can be changed. Press «↵». «ZERO» appears on the screen. Install the sensor according to the item 2.1.2

The value of the potential on the flawless area appears on the screen. After several readings remove the Probe from the control sample, press «↵». The display screen will appear as shown in Figure 6.

Install the sensor according to the item 2.1.3 and make the measurement of the crack depth.

2.4 Power supply control, charging and turning off the device

2.4.1 The device provides a battery discharge control. If the battery is discharged, its image on the screen flashes, then the Crack depth meter turns off.

The battery is charged by the charger, included in the basic delivery set. Charging time is set automatically and at full discharge takes 10 hours, at partial – 5 hours.

2.4.2 The device is switched off by one of the following ways.

2.4.2.1 The device can be turned off by pressing the «ON» button and keeping it pressed for at least 3 seconds. When the «ON» button is released, the device turns off.

2.4.2.2 In the main menu of the operation modes of the device, go to the «OFF» mode and press the «ENTER» button. The device switches off.

2.4.2.3 If the «Auto switch off» is on, the device will turn off automatically, after the programmed time (after the end of the operation time).

3. TECHNICAL MAINTENANCE

3.1. Checking the technical condition of the Crack depth meter in order to ensure its operability during the entire period of operation is carried out at least once a year in the following sequence:

- examine the exterior of the device;
- check the completeness of the device according to p.1.3;
- visually check the serviceability of electronic unit, connecting wires, the state of paint-and-lacquer coatings;
- examination of the Crack depth meter must be carried out in accordance with the «Test Procedure», given in Appendix A.

3.2 The most typical errors of the Crack depth meter and methods for their elimination are shown in Table 4.

Table 4

Type of malfunction	Probable reason	Elimination method
Does not measure the crack depth	There is no Probe contact with the device	Check the integrity of the connecting cable and the correct condition of the connector
Unstable readings	Pollution and corrosion of controlled surface	Clean the controlled surface

4. TRANSPORTATION AND STORAGE

The Crack depth meter is stored in the case in the closed heated room with air temperature $(25\pm 10)^{\circ}\text{C}$, relative humidity from 45 to 80%, atmospheric pressure from 630 to 800 mm Hg.

5. DISPOSAL

The Crack depth meter does not pose a threat to life, to health of people or the environment after the end of life and does not require the special disposal methods.

6. WARRANTY

6.1 The manufacturer guarantees the compliance of 281M Electric potential crack depth meter with the requirements of given Operation manual (combined with the product data sheet), during the warranty period.

The warranty period for the crack depth meter is **12 months from the date of sale, but not more than 15 months from the date of manufacture**, subject to compliance with the requirements of given Operation manual, maintenance, transportation and storage of the device.

6.2 If faults are detected during the warranty period, the consumer should draw up a fault report. The device and the one copy of the fault report have to be sent to the manufacturer or to the supplier (representative of the manufacturer).

6.3 Devices damaged due to violation of operating requirements and precautions during operation as well as requirements to maintenance, transportation and storage are not subject to warranty repair.

6.4 Devices with mechanical damage (with the exception of traces caused by normal operation), as well as traces of liquid ingress, and other influences leading to failure are not subject to warranty repair.

6.5 Devices that show signs of opening and/or attempts of self-repair are not subject to warranty repair.

6.6 The manufacturer's warranty does not apply to batteries and devices from other manufacturers (chargers, grinders, etc.) supplied with 281M Electric potential crack depth meter.

6.7 Warranty and post-warranty repairs of the device are carried out at the manufacturer upon presentation of this Operation manual (combined with the product data sheet).

7. ACCEPTANCE CERTIFICATE

Electro-potential 281M Crack depth meter serial number _____ corresponds to the 281M operating manual OM and is recognized as suitable for operation.

Release date

“ _____ ” _____ 20

Signatures of persons, responsible for acceptance:

ANNEX A

(recommended)

TEST PROCEDURE

The present methodological instructions apply to the electro-potential 281M Crack depth meter, which is designed to control the parts of ferromagnetic steels, and establish the method of its primary and periodic verification.

1. Operations and verification instruments

During the test procedure, the operations are performed and the verification instruments, according to the Table A1, are applied.

Table A1

Operation	Method point number	Verification instruments and normative-technical specifications
External examination of the device and Probe	3.1	
Checking the working capacity of the device	3.2	Special control sample (available on request)
Definition of the measurement errors	3.3	Special control sample (available on request)

2. Calibration conditions and preparation for it

2.1 Following conditions must be observed:

- air temperature in the room $20\pm 5^{\circ}\text{C}$;
- relative humidity in the room $60\pm 15\%$;
- atmospheric pressure 750 ± 30 mmHg

2.2. The working surface of the control sample and the Probe tip must be clean and fat-free (e.g. with alcohol).

2.3 During test procedure, the requirements of the operating documentation for the device must be observed.

3. Calibration conducting

3.1. External inspection of the device and the Probe

3.1.1. All parts of the device, Probe and its accessories must not have the corrosion and traces of the mechanical damages.

3.1.2 The device must have the necessary marking.

3.1.3 The device set must be fully completed.

3.2 Testing the device operational capability

The device operational capability is checked as follows. Perform the operations according to p. 2.2 of the 281M operating

manual on the control sample. Do not write down the result. The device is ready for calibration.

3.3. Determination of the measurement error of the device

3.3.1 The measurement error of the device is determined by means of the control sample (supplied on request), designed to evaluate the error of the Crack depth meter.

3.3.2 Perform five measurements on cracks in depth 1.0, 2.0, 5.0, 10.0, 20.0 and 30.0 mm. Record the measurements results in the protocol.

3.3.3 Based on the results of the five measurements for each depth of the crack, find the arithmetical average (L mes).

3.3.4. Measuring error Δ is defined as the difference between L mes and the value of the crack depth of special control sample (L cr):

$$\Delta = |L \text{ mes} - Lcr|$$

The measurement error must not exceed the limit of the permissible error:

$$\Delta < 0,1Lcr + 0,2$$

3.4 Registration of test procedure results

Calibration results shall be documented in the protocol, the form of which is given in Table A2.

Table A2

Protocol of test procedure - Crack depth meter № _____

Depth of crack of control sample (L cr), mm	Device readings, mm					Arithmetic average (L mes), mm	Measuring error Δ
	1	2	3	4	5		

Testimony: On the basis of test procedure device matches the requirements of operation manual.

Test performed by _____

NPP Mashproject LLC

Phone: +7 (812) 337-55-47

Address: Vatutina street, 17 letter K, Saint-Petersburg, 195009, Russia

**<https://mashproject-ndt.com>
mail@mashproject.ru**